

# OPERATION MANUAL



## **StreetPro SERIES MODEL SP118 PROFESSIONAL PAVEMENT SAW (HONDA GX390U1QWT2 GASOLINE ENGINE)**

Revision #1 (5/3/12)

To find the latest revision of this  
publication, visit our website at:  
[www.multiquip.com](http://www.multiquip.com)



**THIS MANUAL MUST ACCOMPANY THE EQUIPMENT AT ALL TIMES.**

**PN: 38206**

## PROPOSITION 65 WARNING

---



### **CALIFORNIA — Proposition 65 Warning**

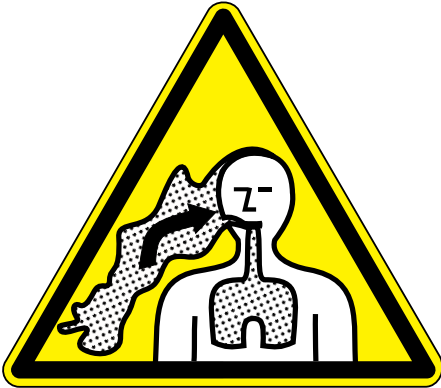
Engine exhaust and some of its constituents, and some dust created by power sanding, sawing, grinding, drilling and other construction activities contains chemicals known to the State of California to cause cancer, birth defects and other reproductive harm. Some examples of these chemicals are:

- Lead from lead-based paints.
- Crystalline silica from bricks.
- Cement and other masonry products.
- Arsenic and chromium from chemically treated lumber.

Your risk from these exposures varies, depending on how often you do this type of work. To reduce your exposure to these chemicals: **ALWAYS** work in a well ventilated area, and work with approved safety equipment, such as dust masks that are specially designed to filter out microscopic particles.

## SILICOSIS/RESPIRATORY WARNINGS

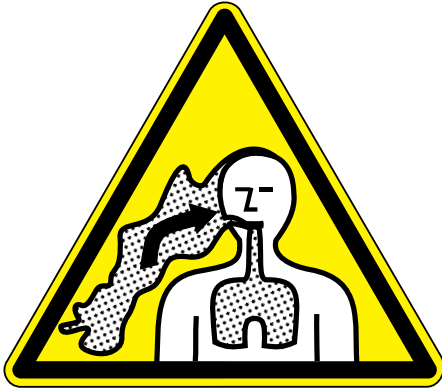
**⚠ WARNING**



**SILICOSIS WARNING**

Grinding/cutting/drilling of masonry, concrete, metal and other materials with silica in their composition may give off dust or mists containing crystalline silica. Silica is a basic component of sand, quartz, brick clay, granite and numerous other minerals and rocks. Repeated and/or substantial inhalation of airborne crystalline silica can cause serious or fatal respiratory diseases, including silicosis. In addition, California and some other authorities have listed respirable crystalline silica as a substance known to cause cancer. When cutting such materials, always follow the respiratory precautions mentioned above.

**⚠ WARNING**



**RESPIRATORY HAZARDS**

Grinding/cutting/drilling of masonry, concrete, metal and other materials can generate dust, mists and fumes containing chemicals known to cause serious or fatal injury or illness, such as respiratory disease, cancer, birth defects or other reproductive harm. If you are unfamiliar with the risks associated with the particular process and/or material being cut or the composition of the tool being used, review the material safety data sheet and/or consult your employer, the material manufacturer/supplier, governmental agencies such as OSHA and NIOSH and other sources on hazardous materials. California and some other authorities, for instance, have published lists of substances known to cause cancer, reproductive toxicity, or other harmful effects.

Control dust, mist and fumes at the source where possible. In this regard use good work practices and follow the recommendations of the manufacturers or suppliers, OSHA/NIOSH, and occupational and trade associations. Water should be used for dust suppression when wet cutting is feasible. When the hazards from inhalation of dust, mists and fumes cannot be eliminated, the operator and any bystanders should always wear a respirator approved by NIOSH/MSHA for the materials being used.

## TABLE OF CONTENTS

---

### SP118 StreetPro

#### Professional Pavement Saw

Proposition 65 Warning .....	2
Silicosis/Respiratory Warnings .....	3
Table Of Contents .....	4
Parts Ordering Procedures.....	5
Training Checklist .....	6
Daily Pre-Operation Checklist .....	7
Safety Information .....	8-14
Dimensions	
Specifications (Saw) .....	16
Specifications (Engine).....	17
General Information.....	18
Components .....	19
Basic Engine.....	20
Inspection/Setup.....	21-23
Blades.....	24-26
Raise/Lower And Depth Stop .....	27
Operation.....	28-31
Maintenance (Saw).....	32
Maintenance (Engine) .....	33
Decommissioning/Water Tank (Optional).....	34
Troubleshooting (Saw).....	35
Troubleshooting (Engine).....	36
Conformity Certificates .....	37

# PARTS ORDERING PROCEDURES

www.multiquip.com

## Ordering parts has never been easier! Choose from three easy options:

Effective:  
January 1<sup>st</sup>, 2006



### Order via Internet (Dealers Only):

Order parts on-line using Multiquip's SmartEquip website!

- View Parts Diagrams
- Order Parts
- Print Specification Information



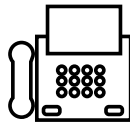
If you have an MQ Account, to obtain a Username and Password, E-mail us at: [parts@multiquip.com](mailto:parts@multiquip.com).

To obtain an MQ Account, contact your District Sales Manager for more information.

Goto [www.multiquip.com](http://www.multiquip.com) and click on **Order Parts** to log in and save!

Use the **internet** and qualify for a **5% Discount** on *Standard orders* for all orders which include complete part numbers.\*

Note: Discounts Are Subject To Change



### Order via Fax (Dealers Only):

All customers are welcome to order parts via Fax.

**Domestic (US) Customers dial:**  
1-800-6-PARTS-7 (800-672-7877)

**Fax** your order in and qualify for a **2% Discount** on *Standard orders* for all orders which include complete part numbers.\*

Note: Discounts Are Subject To Change



**Order via Phone: Domestic (US) Dealers Call:**  
1-800-427-1244

### Non-Dealer Customers:

Contact your local Multiquip Dealer for parts or call 800-427-1244 for help in locating a dealer near you.



**International Customers** should contact their local Multiquip Representatives for Parts Ordering information.

## When ordering parts, please supply:

- |   |  |
|---|--|
| <input type="checkbox"/> Dealer Account Number                                | <input type="checkbox"/> Specify Preferred Method of Shipment:                         |
| <input type="checkbox"/> Dealer Name and Address                              | <input checked="" type="checkbox"/> UPS/Fed Ex <input checked="" type="checkbox"/> DHL |
| <input type="checkbox"/> Shipping Address (if different than billing address) | <input type="checkbox"/> Priority One <input checked="" type="checkbox"/> Truck        |
| <input type="checkbox"/> Return Fax Number                                    | <input type="checkbox"/> Ground  |
| <input type="checkbox"/> Applicable Model Number                              | <input type="checkbox"/> Next Day  |
| <input type="checkbox"/> Quantity, Part Number and Description of Each Part   | <input type="checkbox"/> Second/Third Day  |

### NOTICE

All orders are treated as *Standard Orders* and will ship the same day if received prior to 3PM PST.

WE ACCEPT ALL MAJOR CREDIT CARDS!



## TRAINING CHECKLIST

Training Checklist			
No,	Description	OK?	Date
1	Read operation manual completely.		
2	Machine layout, location of components, checking of engine and hydraulic oil levels.		
3	Fuel system, refueling procedure.		
4	Operation of spray and lights.		
5	Operation of controls (machine not running).		
6	Safety controls, safety stop switch operation.		
7	Emergency stop procedures.		
8	Startup of machine, pre-heat, engine choke.		
9	Forward and reverse travel.		
10	Starting a cut.		
11	Pavement cutting techniques.		
12	Stopping a cut.		
13	Restart after stopping blade within work surface — explanation		
14	Shutdown of machine.		
15	Lifting of machine (lift loops).		
16	Machine transport and storage.		



## DAILY PRE-OPERATION CHECKLIST

Daily Pre-Operation Checklist		✓	✓	✓	✓	✓	✓
1	Hardware and damage check						
2	Engine oil level						
3	Hydraulic oil level						
4	Condition of blade						
5	Safety stop switch operation						
6	Braking control operation						

## SAFETY INFORMATION

Do not operate or service the equipment before reading the entire manual. Safety precautions should be followed at all times when operating this equipment. Failure to read and understand the safety messages and operating instructions could result in injury to yourself and others.



### SAFETY MESSAGES

The four safety messages shown below will inform you about potential hazards that could injure you or others. The safety messages specifically address the level of exposure to the operator and are preceded by one of four words: **DANGER**, **WARNING**, **CAUTION** or **NOTICE**.

### SAFETY SYMBOLS

<b>DANGER</b>
Indicates a hazardous situation which, if not avoided, <b>WILL</b> result in <b>DEATH</b> or <b>SERIOUS INJURY</b> .

<b>WARNING</b>
Indicates a hazardous situation which, if not avoided, <b>COULD</b> result in <b>DEATH</b> or <b>SERIOUS INJURY</b> .

<b>CAUTION</b>
Indicates a hazardous situation which, if not avoided, <b>COULD</b> result in <b>MINOR</b> or <b>MODERATE INJURY</b> .

<b>NOTICE</b>
Addresses practices not related to personal injury.

Potential hazards associated with the operation of this equipment will be referenced with hazard symbols which may appear throughout this manual in conjunction with safety messages.

Symbol	Safety Hazard
	Lethal exhaust gas hazards
	Explosive fuel hazards
	Burn hazards
	Rotating parts hazards
	Cutting and crushing hazards
	Hydraulic fluid hazards



# SAFETY INFORMATION

## GENERAL SAFETY

### CAUTION

- **NEVER** operate this equipment without proper protective clothing, shatterproof glasses, respiratory protection, hearing protection, steel-toed boots and other protective devices required by the job or city and state regulations.



- Avoid wearing jewelry or loose fitting clothes that may snag on the controls or moving parts as this can cause serious injury.

- **NEVER** operate this equipment when not feeling well due to fatigue, illness or when under medication.



- **NEVER** operate this equipment under the influence of drugs or alcohol.



- **ALWAYS** clear the work area of any debris, tools, etc. that would constitute a hazard while the equipment is in operation.

- No one other than the operator is to be in the working area when the equipment is in operation.

- **DO NOT** use the equipment for any purpose other than its intended purposes or applications.

### NOTICE

- This equipment should only be operated by trained and qualified personnel 18 years of age and older.
- Whenever necessary, replace nameplate, operation and safety decals when they become difficult read.
- Manufacturer does not assume responsibility for any accident due to equipment modifications. Unauthorized equipment modification will void all warranties.
- **NEVER** use accessories or attachments that are not recommended by Multiquip for this equipment. Damage to the equipment and/or injury to user may result.
- **ALWAYS** know the location of the nearest **fire extinguisher**.
- **ALWAYS** know the location of the nearest **first aid kit**.
- **ALWAYS** know the location of the nearest phone or **keep a phone on the job site**. Also, know the phone numbers of the nearest **ambulance, doctor and fire department**. This information will be invaluable in the case of an emergency.



## SAFETY INFORMATION

### SAW SAFETY

#### DANGER

- Engine fuel exhaust gases contain poisonous carbon monoxide. This gas is colorless and odorless, and can cause death if inhaled.
- The engine of this equipment requires an adequate free flow of cooling air. **NEVER** operate this equipment in any enclosed or narrow area where free flow of the air is restricted. If the air flow is restricted it will cause injury to people and property and serious damage to the equipment or engine.



- **NEVER** operate the equipment in an explosive atmosphere or near combustible materials. An explosion or fire could result causing severe **bodily harm or even death.**



#### WARNING

- If applicable, **NEVER** use your hand to find hydraulic leaks. Use a piece of wood or cardboard. Hydraulic fluid injected into the skin must be treated by a knowledgeable physician immediately or severe injury or death can occur.
- Accidental starting can cause severe injury or death. **ALWAYS** place the ON/OFF switch in the OFF position.
- **NEVER** disconnect any **emergency or safety devices.** These devices are intended for operator safety. Disconnection of these devices can cause severe injury, bodily harm or even death. Disconnection of any of these devices will void all warranties.



#### CAUTION

- Anytime the saw is lifted onto its nose or tilted fully back, such as for maintenance access, the high end of the saw **MUST** be blocked up to prevent the possibility of crush injury.

#### NOTICE

- **ALWAYS** ensure saw is **securely** placed on appropriate blocks or jackstands when performing maintenance requires elevation of the saw.
- If saw has brakes, ensure brakes are applied when leaving or when using on a slope. Some saws utilize a brake system where the brakes are automatically applied when the engine is stopped.
- If saw has a parking brake, ensure that the parking brake is engaged and holds the saw safely in place when parking on a slope.. Turning the saw across the angle of the slope will help prevent accidental downhill movement.
- **ALWAYS** block the saw with appropriate blocks when leaving the saw parked on a slope.
- To prevent unexpected loss of control, **DO NOT** start engine on a sloping surface
- **DO NOT** use on excessive slopes or on extremely uneven surfaces
- **ALWAYS** start engine with the control handle in NEUTRAL position to prevent unexpected movement.
- **ALWAYS** keep the machine in proper running condition.
- Fix damage to machine and replace any broken parts immediately.
- Make sure there is no buildup of concrete, grease, oil or debris on the machine.
- **ALWAYS** store equipment properly when it is not being used. Equipment should be stored in a clean, dry location out of the reach of children and unauthorized personnel.

## SAFETY INFORMATION

### BLADE SAFETY

#### ⚠ WARNING

- Rotating blade can cut and crush. **ALWAYS** keep hands and feet clear while operating the saw.



#### ⚠ CAUTION

- **NEVER** operate the saw without blade guards and covers in place. Exposure of the diamond blade must not exceed 180 degrees.
- Verify the engine start switch is set to the OFF position before installing a blade.
- **ALWAYS** inspect blade before each use. The blade should exhibit no cracks, dings, or flaws in the steel centered core and/or rim. Center (arbor) hole must be undamaged and true.



#### NOTICE

- Use proper blades and follow blade manufacturer's recommendations. Match the blade RPM (blade shaft RPM) to the recommended blade surface feet per minute (SFPM).
- Ensure the 5/8" blade-mounting bolt is tightened to 125-175 foot lbs. of torque.
- **ALWAYS** examine blade flanges for damage and excessive wear.
- Ensure the blade is marked with an operating speed greater than the spindle speed of the saw.
- Only cut the material that is specified for the diamond blade. Read the specification of the diamond blade to ensure the proper tool has been matched to the material being cut.
- If wet cutting, ensure a **WET CUTTING** blade is being used and that the water supply system to the blade is properly functioning and being used.

- **DO NOT** drop the diamond blade on ground or surface.
- Ensure that the blade is mounted for proper operating direction.
- Adhere to the blade manufacturer's recommendations on handling, storage and safe usage of blades.

### ENGINE SAFETY

#### ⚠ WARNING

- **DO NOT** place hands or fingers inside engine compartment when engine is running.
- **NEVER** operate the engine with heat shields or guards removed.
- Keep fingers, hands hair and clothing away from all moving parts to prevent injury.
- **ALWAYS** shut down the engine before performing service or maintenance.
- **DO NOT** remove the engine oil drain plug while the engine is hot. Hot oil will gush out of the oil tank and severely scald any persons in the general area of the saw.



#### ⚠ CAUTION

- **NEVER** touch the hot exhaust manifold, muffler or cylinder. Allow these parts to cool before servicing equipment.
- Make certain the operator knows how to and is capable of turning the engine OFF in case of an emergency.



#### NOTICE

- **NEVER** run engine without an air filter or with a dirty air filter. Severe engine damage may occur. Service air filter frequently to prevent engine malfunction.
- **NEVER** tamper with the factory settings of the engine or engine governor. Damage to the engine or equipment can result if operating in speed ranges above the maximum allowable.

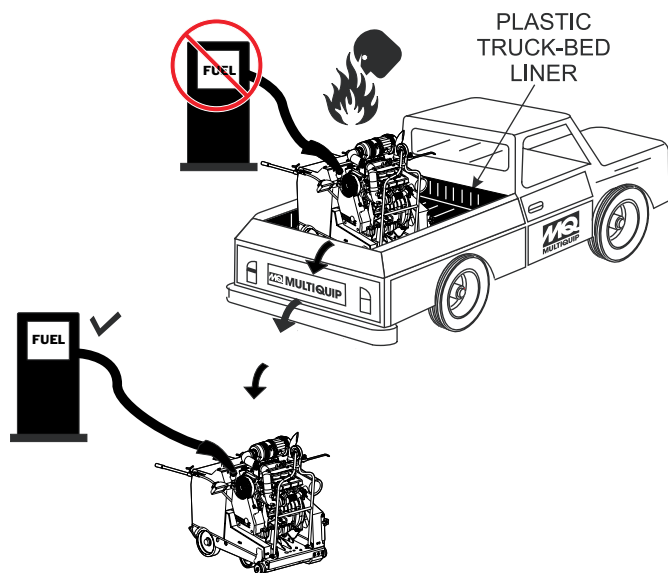



## SAFETY INFORMATION

### FUEL SAFETY

#### DANGER


- **DO NOT** add fuel to equipment if it is placed inside truck bed with plastic liner. Possibility exists of explosion or fire due to static electricity




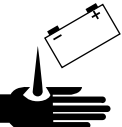
- **DO NOT** start the engine near spilled fuel or combustible fluids. Fuel is extremely flammable and its vapors can cause an explosion if ignited.
- **ALWAYS** refuel in a well-ventilated area, away from sparks and open flames.
- **ALWAYS** use extreme caution when working with **flammable** liquids.
- **DO NOT** fill the fuel tank while the engine is running or hot.
- **DO NOT** overfill tank, since spilled fuel could ignite if it comes into contact with hot engine parts or sparks from the ignition system.
- Store fuel in appropriate containers, in well-ventilated areas and away from sparks and flames.
- **NEVER** use fuel as a cleaning agent.
- **DO NOT** smoke around or near the equipment. Fire or explosion could result from fuel vapors or if fuel is spilled on a hot engine. 

### BATTERY SAFETY (ELECTRIC START ONLY)

#### DANGER

- **DO NOT** drop the battery. There is a possibility that the battery will explode.
- **DO NOT** expose the battery to open flames, sparks, cigarettes, etc. The battery contains combustible gases and liquids. If these gases and liquids come into contact with a flame or spark, an explosion could occur. 

#### WARNING

- **ALWAYS** wear safety glasses when handling the battery to avoid eye irritation. The battery contains acids that can cause injury to the eyes and skin. 
- Use well-insulated gloves when picking up the battery.
- **ALWAYS** keep the battery charged. If the battery is not charged, combustible gas will build up.
- **DO NOT** charge battery if frozen. Battery can explode. When frozen, warm the battery to at least 61°F (16°C).
- **ALWAYS** recharge the battery in a well-ventilated environment to avoid the risk of a dangerous concentration of combustible gases.
- If the battery liquid (dilute sulfuric acid) comes into contact with **clothing or skin**, rinse skin or clothing immediately with plenty of water. 
- If the battery liquid (dilute sulfuric acid) comes into contact with **eyes**, rinse eyes immediately with plenty of water and contact the nearest doctor or hospital to seek medical attention.

#### CAUTION

- **ALWAYS** disconnect the **NEGATIVE** battery terminal before performing service on the equipment.
- **ALWAYS** keep battery cables in good working condition. Repair or replace all worn cables.

## SAFETY INFORMATION

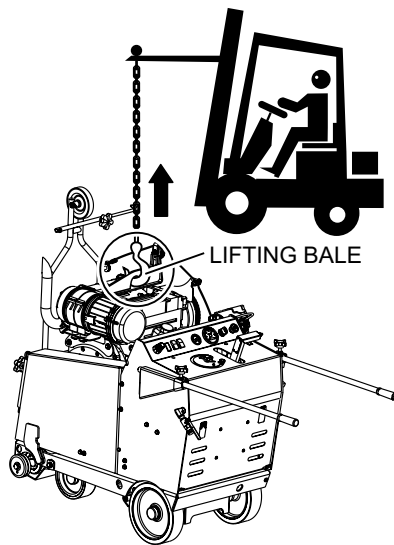
### LIFTING SAFETY

#### **CAUTION**

- **NEVER** allow any person or animal to stand underneath the equipment while lifting.
- Some saws are very heavy and awkward to move around. Use proper heavy lifting procedures.
- **DO NOT** attempt to lift the saw by the guards, handle bars or front pointers.

#### **NOTICE**

- The easiest way to lift the saw is to utilize the lifting bale. A strap or chain can be attached to the lifting bale, allowing a forklift or crane to lift the saw up onto and off of a slab of concrete. The strap or chain should have a minimum of 2,000 pounds (1,000 kg) lifting capacity and the lifting gear must be capable of lifting at least this amount.
- Before lifting, make sure that the lifting bale is not damaged.
- Use one point suspension hook and lift straight upwards.



- **NEVER** tip the engine to extreme angles during lifting as it may cause oil to gravitate into the cylinder head, making the engine start difficult.
- Always make sure crane or lifting device has been properly secured to the lifting bale.
- **DO NOT** lift machine to unnecessary heights.
- **NEVER** lift the equipment while the engine is running.
- **ALWAYS** use ramps capable of supporting the weight of the saw and the operator to load and unload the saw.

### TRANSPORTING SAFETY

#### **NOTICE**

- **ALWAYS** shutdown engine before transporting.
- Tighten fuel tank cap securely and close fuel cock to prevent fuel from spilling.
- **ALWAYS** tie down equipment during transport by securing the equipment with rope.
- Ensure that the diamond blade does not come into contact with the ground or surface during transportation.
- **NEVER** transport the saw to or from the job site with the blade mounted.

## SAFETY INFORMATION

### ENVIRONMENTAL SAFETY/DECOMMISSIONING

#### NOTICE

Decommissioning is a controlled process used to safely retire a piece of equipment that is no longer serviceable. If the equipment poses an unacceptable and unrepairable safety risk due to wear or damage or is no longer cost effective to maintain (beyond life-cycle reliability) and is to be decommissioned (demolition and dismantlement), be sure to follow rules below.

- **DO NOT** pour waste or oil directly onto the ground, down a drain or into any water source.
- Contact your country's Department of Public Works or recycling agency in your area and arrange for proper disposal of any electrical components, waste or oil associated with this equipment.
- When the life cycle of this equipment is over, remove battery and bring to appropriate facility for lead reclamation. Use safety precautions when handling batteries that contain sulfuric acid.
- When the life cycle of this equipment is over, it is recommended that the trowel frame and all other metal parts be sent to a recycling center.



Metal recycling involves the collection of metal from discarded products and its transformation into raw materials to use in manufacturing a new product.

Recyclers and manufacturers alike promote the process of recycling metal. Using a metal recycling center promotes energy cost savings.

### EMISSIONS INFORMATION

#### NOTICE

The gasoline engine used in this equipment has been designed to reduce harmful levels of carbon monoxide (CO), hydrocarbons (HC) and nitrogen oxides (NOx) contained in gasoline exhaust emissions.

This engine has been certified to meet US EPA Evaporative emissions requirements in the installed configuration.

Attempting to modify or make adjustments to the engine emission system by unauthorized personnel without proper training could damage the equipment or create an unsafe condition.

Additionally, modifying the fuel system may adversely affect evaporative emissions, resulting in fines or other penalties.

#### Emission Control Label

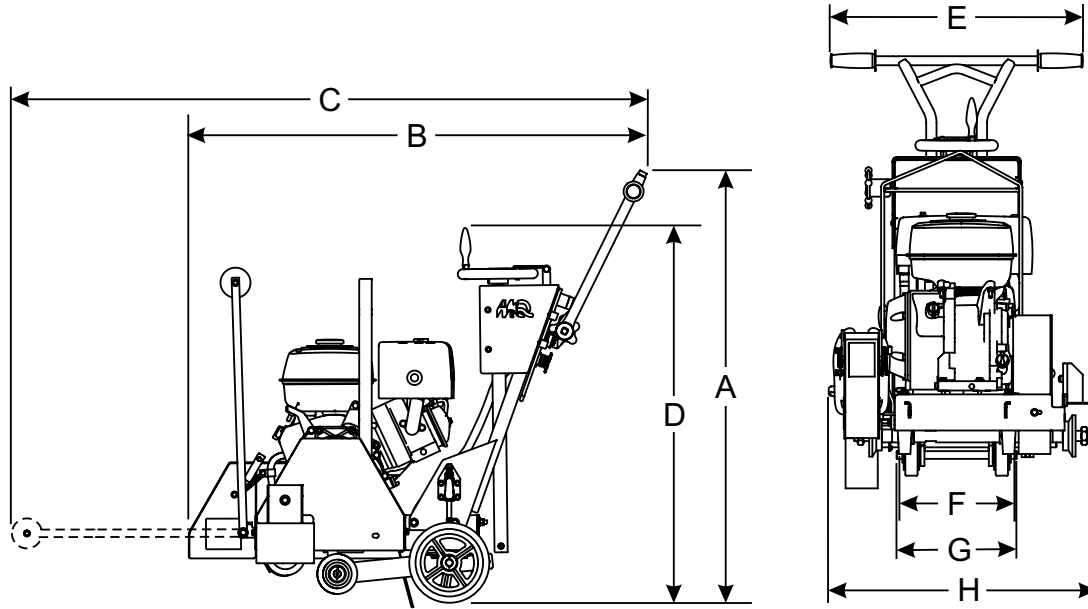
The emission control label is an integral part of the emission system and is strictly controlled by regulation(s).

The label must remain with the engine for its entire life.

If a replacement emission label is needed, please contact your authorized Honda Engine Distributor.



## DIMENSIONS/SPECIFICATIONS



**Figure 1. SP118 Dimensions**

Table 1. Dimensions		
REFERENCE LETTER	DESCRIPTION	DIMENSION
A	Height w/handle– in. (cm)	43.00 (109 cm)
B	Length w/pointer raised – in. (cm)	46.0" (117 cm)
C	Length w/pointer lowered – in. (cm)	67.0" (170 cm)
D	Height w/o handle– in. (cm)	37.0" (94 cm)
E	Width – in. (cm)	25.0" (64 cm)
F	Rear Wheel Base – in. (cm)	17.0" (40 cm)
G	Front Wheel Base – in. (cm)	10.0" (25.4 cm)
H	Handle Bar Width – in. (cm)	24.5" (40 cm)

Table 2. Saw Specifications	
Model	SP118
Maximum Spindle RPM	2836 RPM
Arbor Size	1.0" (2.54 cm)
Maximum Cutting Depth in. (cm)	7.0" (17.78 cm)
Maximum Operating Mass	274 lbs. (124.3)
Nominal Mass (without blade or fluids)	259 lbs. (117.5)



## SPECIFICATIONS

Table 3. Noise and Vibration Emissions	
Guaranteed ISO 11201:2010 Based Sound Pressure Level at Operator Station in dB(A)	93
Guaranteed ISO 3744:2010 Based Sound Power Level in dB(A)	107
Hand-Arm Vibration Per ISO 5349-1:200 in $m/s^2 \Sigma A(8)$	2.27

### NOTES:

1. Sound Pressure and Power Levels are "A" weighted Measures per ISO 226:2003 (ANSI S1.4-1981). They are measured with the operating condition of the machine which generates the most repeatable but highest values of the sound levels. Under normal circumstances, the sound level will vary depending on the condition of the material being worked upon.
2. The vibration level indicated is the vector sum of the RMS (Root Mean Square) Values of amplitudes on each axis, standardized to an 8 hour exposure period, and obtained using operating condition of the machine that generates the most repeatable but highest values in accordance with the applicable standards for the machine.
3. Per EU Directive 2002/44/EC, the daily exposure action value for hand-arm vibration is  $2.5 m/s^2 \Sigma A(8)$ . The daily exposure limit value is  $5 m/s^2 \Sigma A(8)$ .

Table 4. Engine Specifications		
<b>Engine</b>	<b>Model</b>	<b>HONDA GX390U1QWT2</b>
	Type	Air-cooled 4 stroke, Single cylinder, OHV, Gasoline Engine
	Bore x Stroke	3.5 in. x 2.5 in. (88 mm x 64 mm)
	Displacement	23.7 cu-in. (389 cc)
	Net HP Output	11 HP (8.2 kW) @3600 rpm
	Fuel Tank Capacity	Approx. 1.72 U.S. Gallons (6.5 Liters)
	Fuel	Unleaded Automobile Gasoline 86 Octane or higher
	Lube Oil Capacity	1.16 U.S. qt. (1.1 liter)
	Speed Control Method	3.1 in. (78 mm)
	Engine Oil Capacity	Centrifugal Fly-weight Type
Dry Net Weight		68.3 lbs. (31.0 Kg)
Dimensions (L x W x H)		16.7 in. x 17.7 in. x 17.4 in. (425 mm x 450 mm x 443 mm).

## GENERAL INFORMATION

### INTENDED USE

Operate the SP118 Saw, tools and components in accordance with the manufacturer's instructions. Use of any other tools for stated operation is considered contrary to designated use. The risk of such use lies entirely with the user. The manufacturer cannot be held liable for damages as a result of misuse.

### GENERAL INFORMATION

The MQ SP118 Saws are designed for wet or dry cutting of concrete or asphalt utilizing Diamond Blades. These saws have been engineered for general and industrial flat sawing applications. The reinforced steel box frame design adds strength necessary to reduce blade vibrations while cutting. By minimizing blade vibrations the performance of the blade is enhanced and thus the life of the blade is extended.

Heavy-duty front and rear axles, sturdy oversized wheels, and industrial undercarriage assembly ensure accurate tracking and years of reliable use.

Additionally, the general strength-to-weight ratio design of the frame and chassis assembly provides for optimum weight distribution to keep the blade running true in the cut. A rugged spindle bearing assembly ensures minimal flutter and shaft harmonics providing the most advantageous condition for a diamond blade at operating speeds.

This saw comes equipped with an 18-inch blade guard and handles Diamond Blades ranging in size from 12-18-inches in diameter.



**Figure 2. SP118 Saw**

### POWER PLANTS

The SP118 saw is generally considered a "low" powered saw in the industry. This classification is particularly useful when selecting the proper diamond blade for an application.

This SP118 saw is powered by a HONDA GX390U1QWT2 air cooled, 4-stroke, single cylinder, OHV gasoline engine rated at 11 HP (8.2 kW) at 3,600 RPM.

Refer to the HONDA Engine Owner's Manual for specific information regarding engine operation and maintenance procedures.

### BLADE ROTATION

Three premium 3VX belts connecting a properly sized drive (engine) pulley and an output blade shaft pulley provides the rotational power of the diamond blade. Specific pulley diameters have been chosen to support the design of the SP118 saw.

Ultimate blade shaft RPM speed is very important for the safe, efficient operation of the diamond blade in the cut.

**All SP118 SAWS are designed, engineered and manufactured with strict adherence to American National Standards Institute, Inc. (ANSI) guidelines B7.1 and B7.5.**

### FEATURES

- Powerful HONDA GX390 Gasoline engine with cyclone air filtration.
- Adjustable Anti-Vibration Handle Bar.
- Easy adjusting Raise/Lower System with Positive Depth Lock.
- Infinite adjusting Depth Feed Gauge.
- Over-center Lifting Bale.
- Left **OR** Right side sawing.
- Hinged front Blade Guard.
- Rugged Pointer Tracking Arm.
- Super-rigid steel box frame.
- Manual Wheel Brake.
- Water delivery system for Left/Right hand sawing.

## COMPONENTS

For quick reference, Figure 3 highlights basic features of the SP118 Saw.

1. **Engine Stop Switch** — Located on the handle bar, easy toggle to STOP engine.
2. **Anti-Vibration Handle Bar** — Assists in the harmonic damping of the saw. Adjustable in height and collapses flush against the saw frame for efficient storage.
3. **Water Connector** — Standard garden hose connector station to deliver cooling water to the blade.
4. **Wrench (1.5" Box-end)** — Use when removing the Blade Shaft Nut.
5. **Latch** — Raise/Lower mechanical STOP.
6. **Raise/Lower Hand Wheel** — *Clockwise* to raise blade out of cut — *Counter-clockwise* to lower blade into cut .
7. **Parking Brake** — Mechanical clamping stop.
8. **Wheels** — Heavy-duty roller wheel bearings with grease fitting.
9. **Flange Cover** — Guard required for protection as the flange rotates during operations.
10. **Blade Guard** — Covers saw blade and flips up to allow blade changes. Must be kept in place during sawing operations.
11. **Front Pointer** — Adjustable device to allow accurate blade tracking during sawing operations.
12. **Engine** — HONDA GX390 Gasoline Engine with Cyclone air filtration and oil alert systems.
13. **Lifting Bale** — Over-center lifting point for safe transportation of saw.

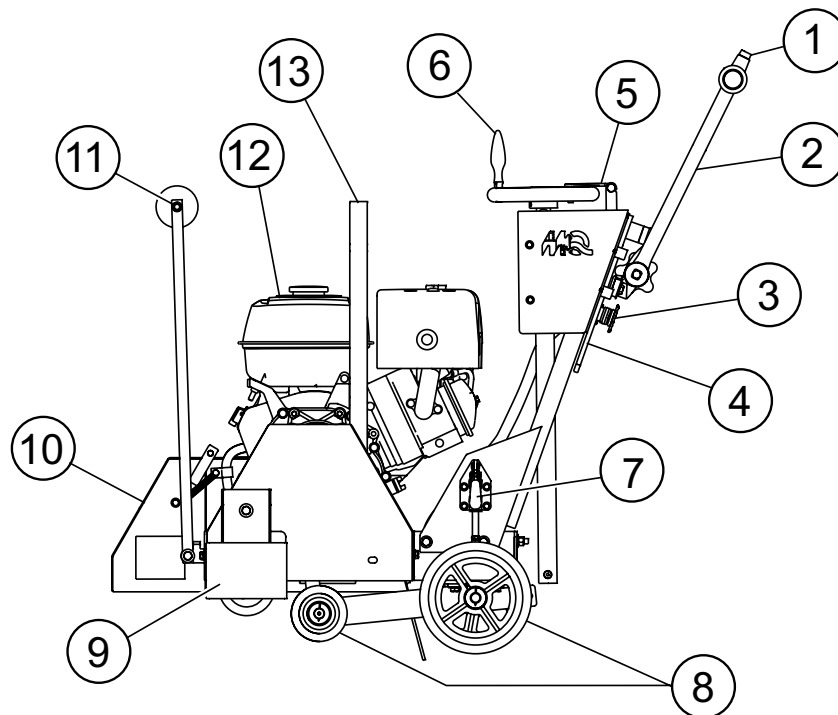
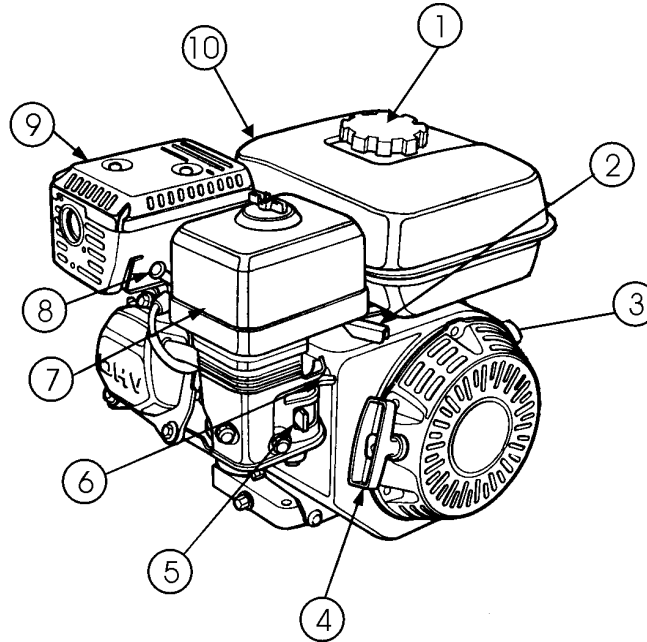


Figure 3. Components

**BASIC ENGINE****Figure 4. Engine Components**

The engine (Figure 4) must be checked for proper lubrication and filled with fuel prior to operation. Refer to the manufacturer's engine manual for instructions & details of operation and servicing.

1. **Fuel Filler Cap** — Remove this cap to add unleaded gasoline to the fuel tank. Make sure cap is tightened securely. **DO NOT** over fill.

**! DANGER**

Adding fuel to the tank should be done only when the engine is stopped and has had an opportunity to cool down. In the event of a fuel spill, **DO NOT** attempt to start the engine until the fuel residue has been completely wiped up, and the area surrounding the engine is dry.

2. **Throttle Lever** — Used to adjust engine RPM speed (lever advanced forward **SLOW**, lever back toward operator **FAST**).
3. **Engine ON/OFF Switch** — **ON** position permits engine starting, **OFF** position stops engine operations.
4. **Recoil Starter (pull rope)** — Manual-starting method. Pull the starter grip until resistance is felt, then pull briskly and smoothly.

5. **Fuel Valve Lever** — **OPEN** to let fuel flow, **CLOSE** to stop the flow of fuel.

6. **Choke Lever** — Used in the starting of a cold engine, or in cold weather conditions. The choke enriches the fuel mixture.

7. **Air Cleaner** — Prevents dirt and other debris from entering the fuel system. Remove wing-nut on top of air filter cannister to gain access to filter element.

**NOTICE**

Operating the engine without an air filter, with a damaged air filter, or a filter in need of replacement will allow dirt to enter the engine, causing rapid engine wear.

8. **Spark Plug** — Provides spark to the ignition system. Clean spark plug once a month.

9. **Muffler** — Used to reduce noise and emissions.

**! WARNING**

Engine components can generate extreme heat. To prevent burns, **DO NOT** touch these areas while the engine is running or immediately after operating. **NEVER** operate the engine with the muffler removed.

10. **Fuel Tank** — Holds unleaded gasoline. For additional information refer to engine owner's manual.

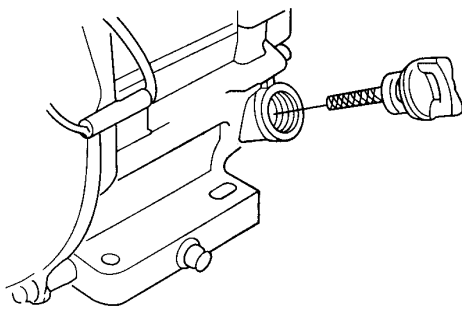
## INSPECTION/SETUP

### INSPECTION/SETUP

1. Read and fully understand this manual, the safety instructions in particular, and the engine manufacturer's manual supplied with the saw.
2. Select the correct blade for each application. Refer to the Blades and Blade Placement sections on pages 20 through 22 for further information.
3. Check blade for wear or damage. Handle all blades with care and ALWAYS replace a damaged blade. Clean the saw, removing dirt and dust, particularly the engine cooling air inlet, carburetor and air cleaner.
4. Check the air filter for dirt and dust. Replace the air filter if it is found to be dirty.
5. Check carburetor for external dirt and dust. Clean with dry compressed air.
6. Check fastening nuts and bolts for tightness.
7. Ensure a suitable water supply is available, hooked up, and used. (connected via garden hose or with an optional water tank supply system).

### Engine Oil Check

1. To check the engine oil level, place the saw on secure level ground with the engine stopped. The frame platform must be **level to** accurately check the engine oil.
2. Remove the filler dipstick from the engine oil filler hole (Figure 5) and wipe it clean.

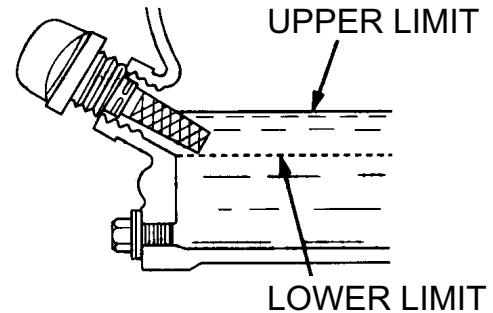


**Figure 5. Engine Oil Dipstick (Removal)**

3. Insert and remove the dipstick without screwing it into the filler neck. Check the oil level shown on the dipstick.
4. If the oil level is low (Figure 6), fill to the edge of the oil filler hole with the recommended oil type (Table 5).

### NOTICE

Reference manufacturer engine manual for specific servicing instructions.



**Figure 6. Oil Level**

**Table 5. Oil Type**

Season	Temperature	Oil Type
Summer	25°C or Higher	SAE 10W-30
Spring/Fall	25°C ~ 10°C	SAE 10W-30/20
Winter	25°C or Lower	SAE 10W-10

### Fuel Check

1. Remove the gasoline cap located on top of fuel tank.

### WARNING



Motor fuels are highly flammable and can be dangerous if mishandled. **DO NOT** smoke while refueling. **DO NOT** attempt to refuel the saw if the engine is hot! or running.

2. Visually inspect to see if fuel level is low. If fuel is low, replenish with unleaded fuel.
3. When refueling, be sure to use a strainer for filtration. **DO NOT** top-off fuel. Wipe up any spilled fuel.

## INSPECTION/SETUP

### Guards And Covers

#### ! WARNING



**NEVER** operate the saw without blade guards and covers in place. **DO NOT** operate with the front of the blade guard raised. The blade exposure cannot exceed 180 degrees during operation. Adhere to the safety guidelines or other applicable local regulations.



**Figure 7. Blade Guard (Right-side mounting)**

### Blade Guard Inspection

**CHECK** the following on the **Blade Guard** (Figure 7)

- Ensure the water feed tubes are properly positioned to permit water flow to both sides of the diamond blade.
- Check that the guard is bolted firmly upon the saw frame.
- Check that the spring tensioned front cover of the guard is firmly seated with the rear section of the guard and there are no gaps. **NEVER** lift the blade guard while engine is running.

**ENSURE** the **V-Belt Cover** is in place and securely fastened during operation of the saw (Figure 8).

### V-Belt Check

A worn or damaged V-belt can adversely affect the performance of the saw. If a V-belt is defective or worn, replace **ALL** the V-belts. V-belts should always be replaced in sets.

#### ! WARNING



**NEVER** attempt to check the V-belt with the engine running. Severe injury can occur. Keep fingers, hands, hair, and clothing away from all moving parts.

### V-Belt Alignment and Tensioning

This saw is equipped with premium V-belts that have been aligned and tensioned by factory personnel. The V-belt must be aligned and tensioned for proper operation of the saw.

Use the following procedure to check the alignment of V-belt:

1. Remove the bolts that secure the V-belt cover (Figure 8) to the saw frame.

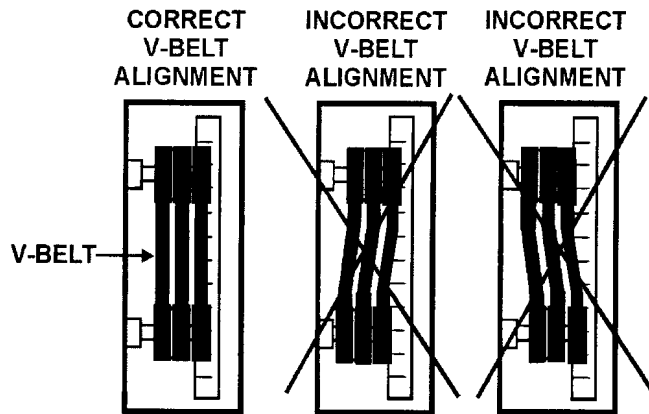


**Figure 8. V-Belt Cover**

2. Check uniform parallelism (Figure 9) of V-belt and pulley (sheaves). Use a straight-edge or machinist's square against both pulleys and adjust both pulleys until equally aligned.

## INSPECTION/SETUP

- Check V-belt tension by using a tension meter (3.0 lbs./1.36Kg) against the inside belt at a mid point between the two pulleys, or by deflecting the center belt at a mid point 3/16" (5 mm).



**Figure 9. V-Belt Alignment**

- DO NOT** over or under tighten the V-belts. Severe damage can occur to the saw and engine crankshaft if the belt is over-tensioned. A decrease of power to the blade and poor performance will result if the belt is under-tensioned (loose on pulleys).

### NOTICE

V-belt alignment must be rechecked after adjusting belt tension.

### SPECIFIC TOOLS TO BE USED

This saw is to use tools (blades) as follows:

- Steel Core Segmented or Continuous Diamond Rim Cutting Wheel.

Any other type of tool is not to be used. See Table 6 for specific blade usage for material.

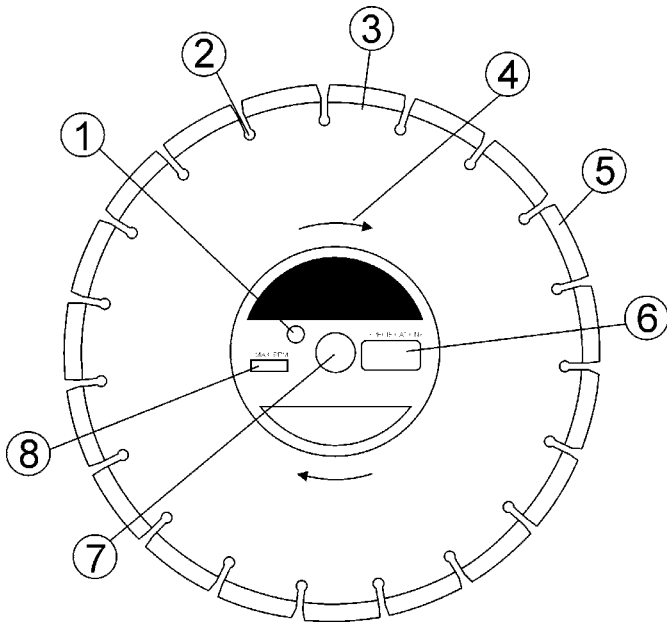
### WARNING



Failure to thoroughly inspect the diamond blade (Figure 10) for operational safety could result in damage to the blade or the saw, and may cause injury to the user or others in the operating area. Discard damaged or worn blades and replace with fresh blade.

**BLADES**

Figure 10 highlights the components of a diamond blade.



**Figure 10. Diamond Blade**

1. **Drive Pin Hole** – A commonly located hole on the diamond blade core that prevents operational blade slippage between the inner & outer blade flanges (collars). Inspect the diameter of the hole to ensure there is no distortion, and that a snug fit develops between the hole and drive pin.
2. **Stress Relief Holes (Gullets)** – Check the steel core for cracks that may have propagated from the slots and/or gullets. Cracks indicate extreme fatigue failure and if sawing continues, catastrophic failure will occur.
3. **Edge Of The Steel Core** – Check the diameter edge for discoloration (blue oxidation) indicating an overheating condition caused by insufficient cooling water/air. Overheating of blades may lead to loss of core tension and/or increase the possibility for blade failure. Check to make sure the steel core's width is uniform about the rim of the blade, and not succumbing to an "under cutting" condition brought about by highly abrasive material or improper under cutting core protection.
4. **Directional Arrow** – Check to ensure that the blade is oriented properly on the spindle for sawing. Reference the directional arrow on the blade and place it so the direction of rotation "downcuts" with the turn of the shaft.
5. **Diamond Segment or Rim** – Ensure there are no cracks, dings, or missing portions of the diamond segment/rim. **DO NOT use a blade that is missing a segment or a portion of the rim.** Damaged and/or missing segments/rims may cause damage to your saw, and injury to the user or others in the operating area.
6. **Specifications** – Ensure that the blade specifications, size, and diameter properly match up to the sawing operation. Wet blades must have water to act as a coolant. Utilizing a diamond blade not matched properly to the task may result in poor performance and/or blade damage.
7. **Arbor Hole** – It is essential that the arbor hole diameter properly matches the shaft arbor, and that it is free from distortions. Correct blade flanges (collars) must be used. The inside face of the flanges must be clean & free of debris. An out of round arbor condition will cause damage to the blade and the saw.
8. **MAX RPM** – This RPM reference is the maximum safe operating speed for the blade selected. **NEVER** exceed the max RPM on the diamond blade. Exceeding the MAX RPM is dangerous, and may cause poor performance and may damage the blade. All blades used must be designed for the maximum spindle RPM.



Table 6. Material Listing And Blade Selection	
Material	Blade
Cured Concrete	Cured Concrete Blade
Green Concrete	Green Concrete Blade
Asphalt	Asphalt Blade
Asphalt over Concrete	Asphalt/Concrete Blade
Block, Brick, Masonry, Refractories	Masonry Blade
Tile, Ceramic, Stone	Tile Blade

## Diamond Blades

Selecting the diamond blade type and grade defines how the blade will perform both in cutting speed and blade life. Selection of the proper diamond blade consists of:


- Material to be Cut
- Type of Saw Being Used
- Horsepower of Saw
- Hardness Characteristics of the Material
- Performance Expectations

Factors for sawing economy:

- Type of Blade
- Depth of Cut
- Sawing Speed
- Characteristics of the Material Being Cut

## Blade Speed

**WARNING**



Operating saw blades at rotational speeds greater than those specified by the manufacture can cause blade damage, and may injure the user or others in the operating area.


A diamond blade's performance is directly connected to specific peripheral (rim) speeds.

The following shaft rotational speeds have been factory set to ensure optimum blade performance:

- SP118 18" Capacity - 2,836 RPM.

## BLADE PLACEMENT

**WARNING**



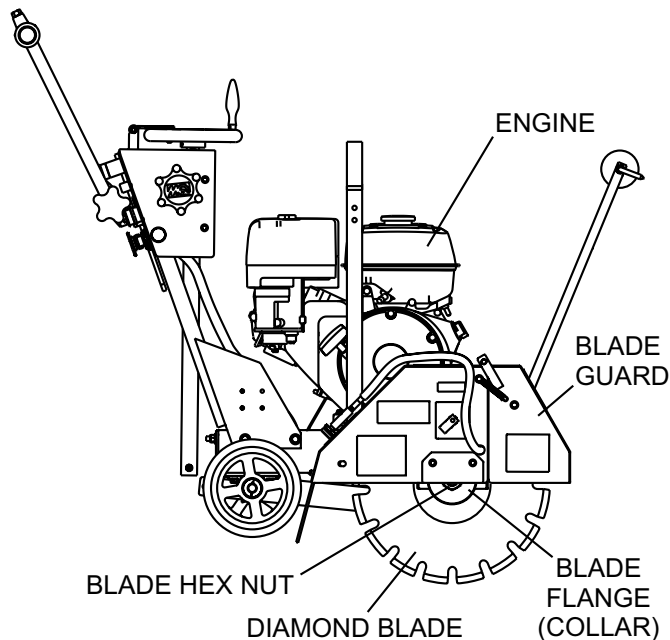
Failure to thoroughly inspect the diamond blade for operational safety could result in damage to the blades or the saw and may cause injury to the user or others in the operating area.

Refer to Figure 11 for the following steps.

1. **Engine OFF** — Set the ENGINE ON/OFF switches to the "OFF" position to prevent accidental starting.
2. **Blade Guard** — Pivot the blade guard front cover all the way back. The guard tension spring will keep the front cover in position.
3. **Blade Hex Nut** — Unscrew the spindle nut (right side loosens clockwise and tightens counter-clockwise while the left side loosens counter-clockwise and tightens clockwise. DO NOT overtighten the nut (approximately 45-50 ft. lb/61-68 N/m) when finalizing the assembly.

**BLADES**

4. **Outside Blade Flange (Collar)** — Ensure that the outside blade flange is placed flush against the diamond blade. The inside surface of the flange must be free of debris and permit a tight closure on the surface of the blade core.
5. **Diamond Blade** — Ensure that the proper diamond blade has been selected for the job. Pay close attention to the directional arrows on the blade. The blade's operating directional arrows must point in a "down-cutting" direction to perform correctly. When placing the blade onto the spindle, ensure the arbor hole of the blade matches the diameter of the shaft.
6. **Inner Flange (Collar)** — This flange is fixed upon the spindle. The inside surface of the flange must be free of debris and permit a tight closure on the surface of the blade.

**Figure 11. Blade Placement****WARNING**

Incorrectly installed blades can cause damage to the blade or equipment or cause injury due to breakage.

**WARNING**

Dropping or forcing the blade onto the cutting surface can severely damage the diamond blade and may cause serious damage to the saw and bodily harm.

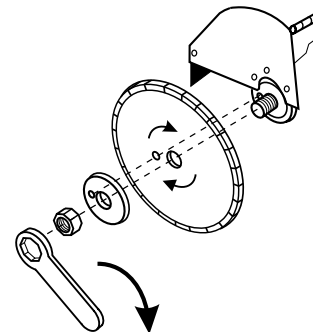
**Blade Removal and Replacement**

1. Set the ENGINE ON/OFF switches to the **OFF** position to prevent accidental starting.
2. Place the saw on a stable level working surface.
3. Ensure the blade is raised and the raise/lower crank is locked into position.

**NOTICE**

When removing or installing a diamond blade, please note that the blade retaining nuts are left and right-hand threaded.

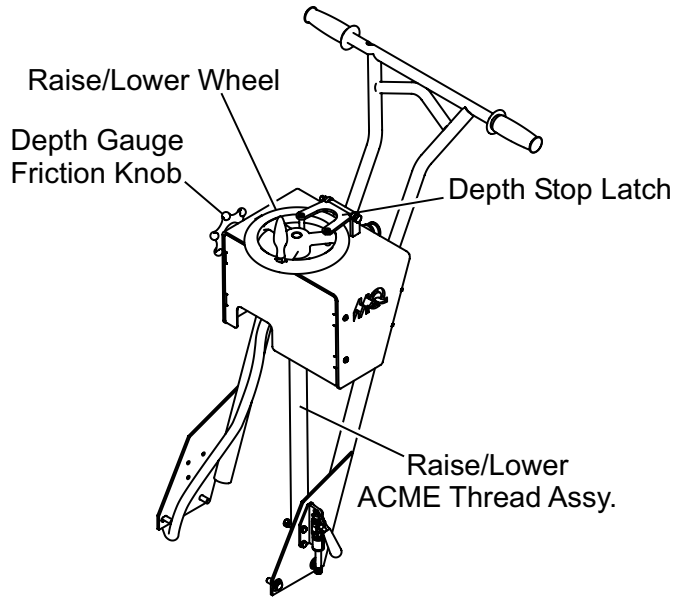
4. Lift up the blade guard cover to gain access to the blade.

**Figure 12. Mounting the Diamond Blade**

5. Use the provided blade nut and spindle locking wrenches to remove and install the blade. (Figure 12)
6. Unscrew the spindle nut (right side loosens clockwise and tightens counter-clockwise while the left side loosens counter-clockwise and tightens clockwise). **DO NOT** over-tighten the nut (approximately 45-50 ft. lb/61-68 N/m) when finalizing the assembly.

## RAISE/LOWER AND DEPTH STOP

Figure 13 highlights the components of the Raise/Lower Depth Stop Assembly.

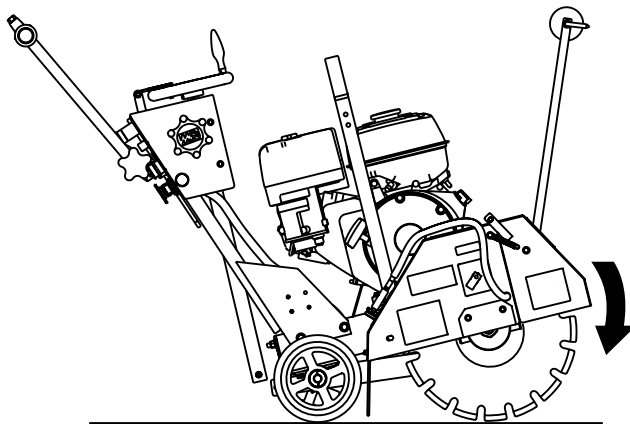


**Figure 13. Raise/Lower Depth Stop**

### Calibrating the Desired Depth of Cut

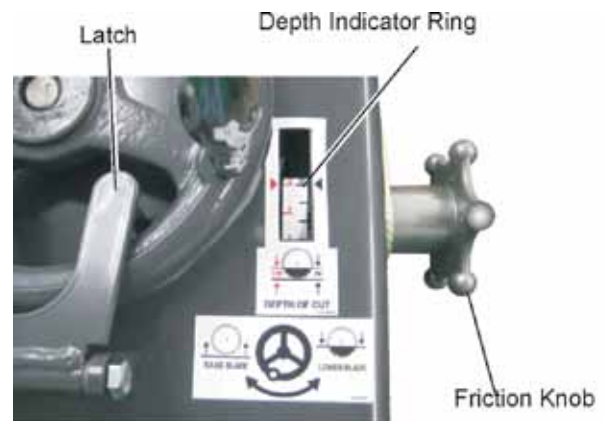
The SP118 provides for infinite depth adjustment with Diamond Blades 12" thru 18" in diameter.

1. Turn Engine to off.
2. Place saw on level ground.
3. Select Diamond Blade and mount the blade according to Figure 12.
4. Lower the blade so it just touches the surface.



**Figure 14. Lowering Blade for Depth of Cut**

5. Position Depth Indicator Ring to "0".
6. Depth Gauge Friction Knob can be adjusted as necessary using locknut inside of console.
7. The Diamond Blade is now oriented.
8. The Depth Indicator Ring now references the depth of cut.
9. Once the blade is at the desired depth during sawing operations, position the Depth Stop Latch within the Raise/Lower Wheel.



**Figure 15. Setting Depth Stop**

**OPERATION****START-UP****CAUTION**

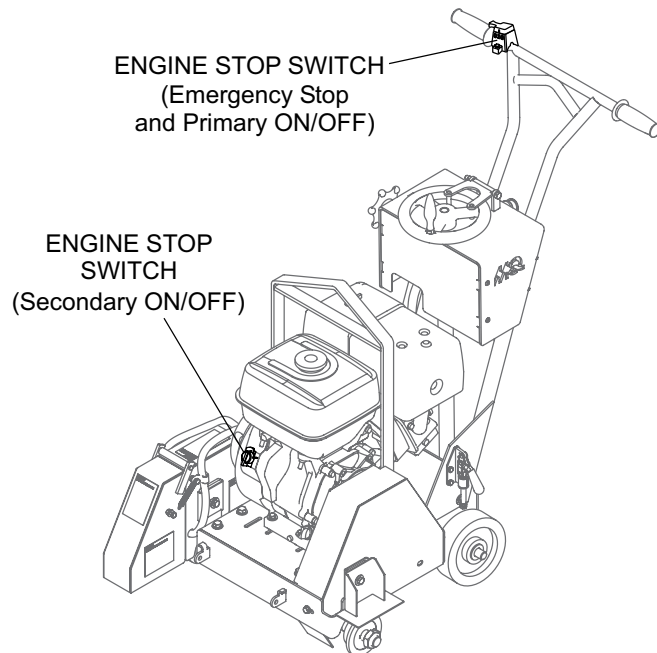
DO NOT attempt to operate the saw until this manual has been read and thoroughly understood. Engine operating steps may vary. See included engine manufacturer's operating manual.

**CAUTION**

Ensure the work area is clear of tools, debris, and unauthorized people.

**NOTICE**

The Engine Stop Switch located on the handlebar (Figure 16) serves both as an Emergency Engine Shut-Off and as the primary ON/OFF switch. This allows the operator to shutdown the saw safely away from moving parts.



**Figure 16. Engine Stop Switches**

**DANGER**

NEVER operate the saw in a confined area or enclosed structure that does not provide an ample free flow of air.

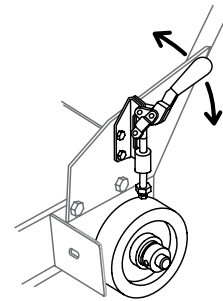
**WARNING**

NEVER place hands or feet inside the belt guard or blade guard while the engine is running. ALWAYS shut the engine down before performing any kind of maintenance service on the saw



ALWAYS wear approved eye and hearing protection while operating the saw.

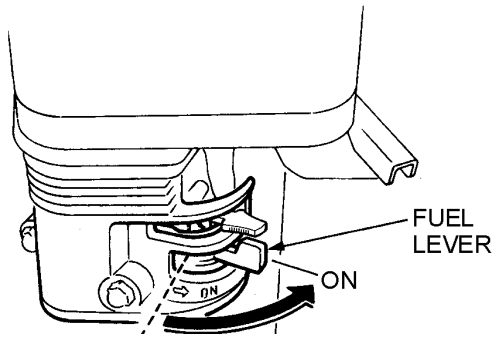
1. Keep Wheel Clamp applied (lever DOWN) until completely ready for cutting operation.



**Figure 17. Parking Brake**

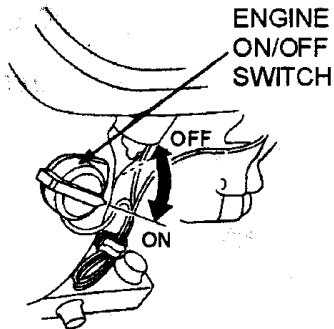
2. Ensure the diamond blade has been mounted correctly and that it is raised above the surface you are about to saw.
3. Place the fuel valve lever (Figure 18) to the "ON" position.

# OPERATION

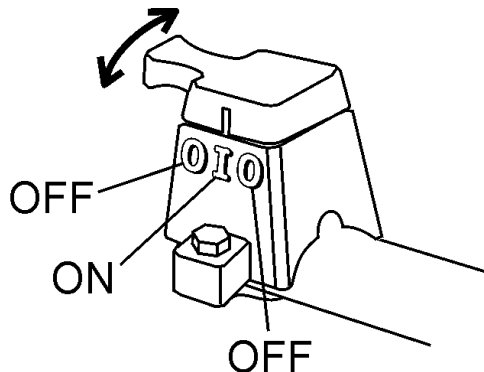


**Figure 18. Engine Fuel Valve Lever**

- Place the ENGINE ON/OFF switch located on the ENGINE (Figure 19) in the "ON" position. Place the ENGINE ON/OFF switch located on the HANDLEBARS (Figure 20) in the "ON" (center) position.



**Figure 19. Engine ON/OFF Switch (On Engine)**

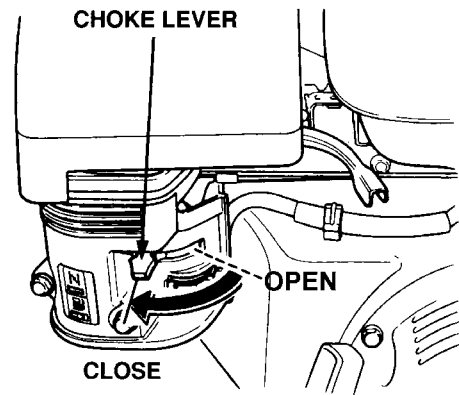


**Figure 20. Engine ON/OFF Switch (On Handlebars)**

- Place the Choke Lever (Figure 21) in the "CLOSED" position.

## NOTICE

The CLOSED position of the choke lever enriches the fuel mixture for starting a COLD engine. The OPEN position provides the correct fuel mixture for normal operation after starting, and for restarting a warm engine.

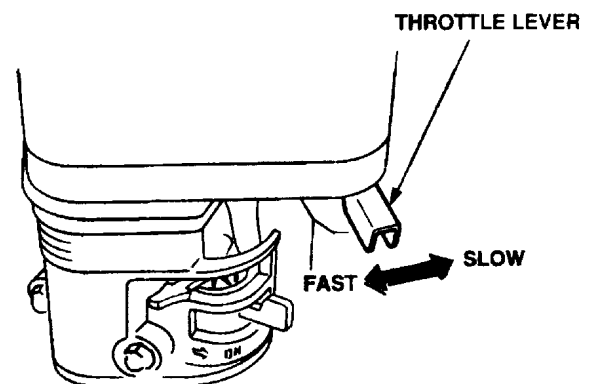


**Figure 21. Choke Lever**

## CAUTION

The engine speed has been set at the factory. Changing the governor speed could damage the blade and/or the saw.

- Rotate the throttle lever (Figure 22) halfway between fast and slow for starting. All sawing is done at full throttle. The engine governor speed is factory set to ensure optimum blade operating speeds.



**Figure 22. Throttle Lever**

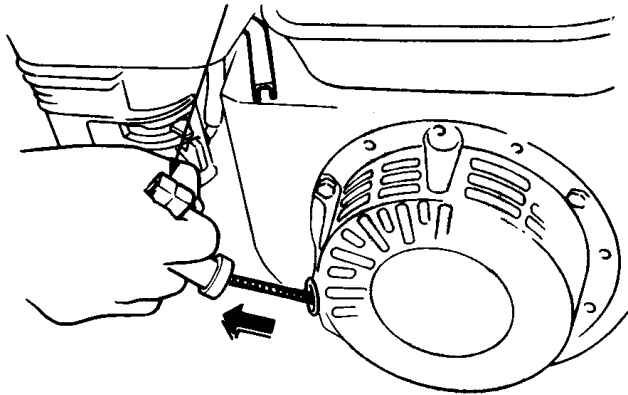
- Grasp the starter grip (Figure 23) and slowly pull it out.

**OPERATION**

The resistance becomes the hardest at the compression point. Pull the starter grip briskly and smoothly for starting.

**CAUTION**

DO NOT pull the starter rope all the way to the end. DO NOT release the starter rope after pulling. Allow it to rewind as soon as possible.

**STARTER GRIP****Figure 23. Starter Grip**

8. If the engine has started, slowly return the choke lever (Figure 21) to the "OPEN" position. If the engine has not started repeat steps 1 through 7.
9. Before the saw is placed into operation, run the engine for several minutes. Check for fuel leaks, and noises that could be associated with loose guards and/or covers.

**OPERATION****WARNING**

- ALWAYS cut with the saw at FULL THROTTLE. Attempting to cut with the saw at less than full throttle could cause the blade to bind or stop abruptly in the slab resulting in serious injury to the operator or others in the area.
- ALWAYS keep clear of rotating or moving parts while operating this equipment.

**CAUTION**

- Ensure the cutting area is clear of tools, debris, and unauthorized people.
- DO NOT try to cut faster than the blade will allow. Cutting too fast will cause the blade to rise up out of the cut. Improper cutting rate can decrease the life of the engine and blades.
- Engine components and the blade can get EXTREMELY HOT! during operation. ALWAYS allow the engine and blade to cool before handling or servicing.
- Whenever the saw is not in operation or being moved or transported, apply the wheel clamp brakes to prevent unwanted displacement.

**NOTICE**

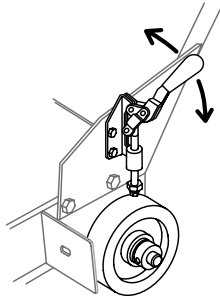
Mark the cutting line clearly and always saw in a STRAIGHT LINE ONLY.

**NOTICE**

The Engine Stop Switch located on the handlebar (Figure 16) serves both as an Emergency Engine Shut-Off and as the primary ON/OFF switch. This allows the operator to shutdown the saw safely away from moving parts.

## OPERATION

1. Connect the saw to your water source and start the engine as described in the previous section.
2. Rotate the throttle lever (Figure 22) to full throttle.
3. Turn the water valve to start the flow of water and ensure sufficient water supply is directed to both sides of the diamond blade.
4. Release Parking Brake by pulling Lever UP.



**Figure 24. Parking Brake**

5. To begin sawing, rotate the Raise/Lower Wheel until the desired depth is referenced on the Depth Indicator Ring.
6. When the blade has reached the desired depth of cut, flip the Depth Stop Latch down into position within the Raise/Lower Wheel.
7. Walk the saw slowly forward at a rate that permits the diamonds to grind without losing optimum blade RPM.
8. When cutting is complete, turn the engine OFF using the ENGINE STOP TOGGLE SWITCH on the handlebars and wait for the blade to stop rotating.
9. Set the engine ON/OFF switch to the OFF position.
10. Place the water valve in the OFF position (as required).
11. Push the Parking Brake Lever downward to apply braking pressure to the wheels.

### RESTARTING AFTER INTERVENTION

If cutting is interrupted where the engine stops or is turned off while the blade is still in the cut:

1. Turn Engine Off switches to **OFF**
2. Raise the blade out of the cut
3. Restart the engine as described in the previous section.
4. Recheck the integrity of the diamond blade.

#### **CAUTION**

The only acceptable method for freeing a stuck blade is to remove the saw from the stuck or pinched blade. **DO NOT** try to get the blade unstuck using the Raise/Lower system or by lifting the saw by the lifting bale, etc.

If cutting is interrupted where the blade is stuck in the cut:

1. Turn Engine Off switches to **OFF**.
2. Remove the blade guard.
3. Remove blade mounting bolt and outer flange.
4. Maneuver the saw away from the stuck blade.
5. A parallel cut made next to the blade may be necessary to free it.
6. Once the blade is freed inspect the blade for damage; discard if damaged.
7. Ensure an undamaged, useable blade is installed on the saw before cutting is resumed with that saw.

## MAINTENANCE (SAW)

### NOTICE



See the engine manual supplied with your machine for appropriate engine maintenance schedule and troubleshooting guide for problems.

General maintenance practices are crucial to the performance and longevity of your saw. The extreme environments of sawing operations require routine cleaning, lubrication, belt tensioning, and inspection for wear and damage.

The following procedures devoted to maintenance can prevent serious saw damage or malfunctioning.

### ! DANGER



Some maintenance operations may require the engine to be run. Ensure that the maintenance area is well ventilated. Exhaust contains poisonous carbon monoxide gas that can cause unconsciousness and may result in DEATH.

### ! WARNING



**NEVER** place hands or feet inside the belt guard or blade guard while the engine is running.



Before servicing or inspection, **ALWAYS** park the saw on a level surface with the blade removed, and the handlebar Engine ON/OFF switch and Engine ON/OFF switch in "OFF" position.

- Removing or installing blades
- Adjusting front or rear pointers
- Lubricating any components
- Removing engine mounting bolts
- Inspecting, adjusting or replacing drivebelt, spindle, spindle bearings or any engine part
- Removing blade or belt guards

### ! CAUTION



**ALWAYS** allow the engine to cool before servicing. **NEVER** attempt any maintenance work on a hot! engine.

### Front Pointer Adjustment

The front pointer wheel has been set at the factory. Use these procedures only if the pointer is suspect of being out of alignment.

1. Chalk out a straight line on the prepared slab or cutting surface.
2. Use a straight-edge or level by placing it flat against the blade.
3. Adjust the front pointer wheel so it just touches the side of the straight-edge or level.
4. Remove the straight-edge or level.
5. Position the front pointer and blade directly over the chalk line.
6. Start the saw and lower the blade onto the chalk line.
7. Begin cutting and make sure the blade follows the chalk line as closely as possible.
8. The pointer should follow the chalk line as well. If it does not, adjust the pointer by loosening then tightening the jam nuts on the pointer until the pointer follows the same path as the blade.

### Chassis Lubrication

- Spindle Bearings - Two zerk fittings are located up under the lower-front of the saw. Lubricate before daily use. Use a good quality extreme pressure grease. Check and lubricate more often if unit is under heavy use. Do not overfill bearings. Overfilling can damage the grease seals. This can result in bearing exposure to dirt and contaminants which can then shorten the life of the bearings. Excess grease can also drip onto the cutting surface.

### General Cleanliness

Clean the machine daily. Remove all dust and slurry build up. If the saw is steam cleaned, ensure that lubrication is accomplished AFTER steam cleaning operations.



## MAINTENANCE (ENGINE)

### GENERAL ENGINE CARE

#### Engine check

Check daily for any oil and/or fuel leakage, thread nut and bolt tightness, and overall cleanliness.

#### Engine air filter

Replace air filter if dirty. See Engine Owner's Manual for detailed information.

#### Engine oil

Check daily. Inspect with blade removed and saw frame level on a level surface. Keep the oil clean, and at the proper servicing level (Figure 6). **DO NOT OVERFILL!** SAE 10W-30 of SG is recommended for general use.

#### Engine oil change

Change engine oil the first month or 20 hours of operation. Then every 3 months/or 50 HOURS of operation. See Engine Owner's Manual for detailed information.

Drain the used oil while the engine is warm by the following method:

Refer to Figure 25.

1. Place an oil pan or suitable container below the engine drain plug to catch the used oil.
2. Remove the filler cap/dipstick and the drain plug.
3. Drain the oil completely and reinstall the drain plug. Ensure the drain plug is tightened securely.
4. Make sure the engine is in a level position and fill to the outer edge of the oil filler hole with the recommended oil (see Table 5.) Engine oil capacity is 1.16 US quart (1.1 liter).
5. Screw in the filler cap/dipstick securely.

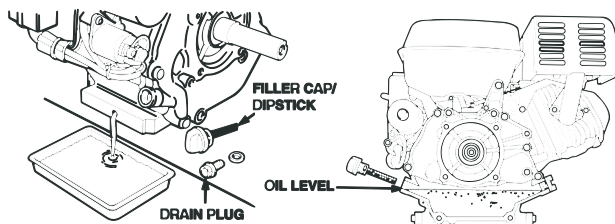


Figure 25. Engine Oil Change

#### **CAUTION**

Running the engine with a low oil level can cause engine damage.

#### **NOTICE**

Dispose of used oil properly. **DO NOT** pour used oil on the ground, down a drain, or throw in the trash. Used oil can generally be taken to your local recycling center or service station for reclamation. Follow all required environmental rules and regulations required in your area concerning the disposal of hazardous waste such as used oil and oil filters.

#### Engine tank and strainer

Clean every year/or 300 hours.

#### Fuel line

Replace every two years/or as necessary.

#### Spark plug

Clean/adjust every 6 months/or 100 hours. Replace every year/ or 300 hours.

## DECOMMISSIONING/WATER TANK (OPTIONAL)

### DECOMMISSIONING SAW/COMPONENTS

Decommissioning is a controlled process used to safely retire a piece of equipment that is no longer serviceable. If the equipment poses an unacceptable and unreparable safety risk due to wear or damage or is no longer cost effective to maintain, (beyond life-cycle reliability) and is to be decommissioned, (demolition and dismantlement), the following procedure must take place:

6. Drain all fluids completely. These may include oil, gasoline, hydraulic oil and antifreeze. Dispose of properly in accordance with local and governmental regulations. Never pour on ground or dump down drains or sewers.
7. Remove battery (if applicable) and bring to appropriate facility for lead reclamation. Use safety precautions when handling batteries that contain sulfuric acid,
8. The remainder can be brought to a salvage yard or metal reclamation facility for further dismantling.

### WATER TANK KIT (OPTION)

An optional water tank kit, (P/N SP1WK) is available for use with the SP118 Saw. See assembly instruction sheet p/n 38265 for the assembly of the kit onto your saw.

The illustration shown below is provided for reference.

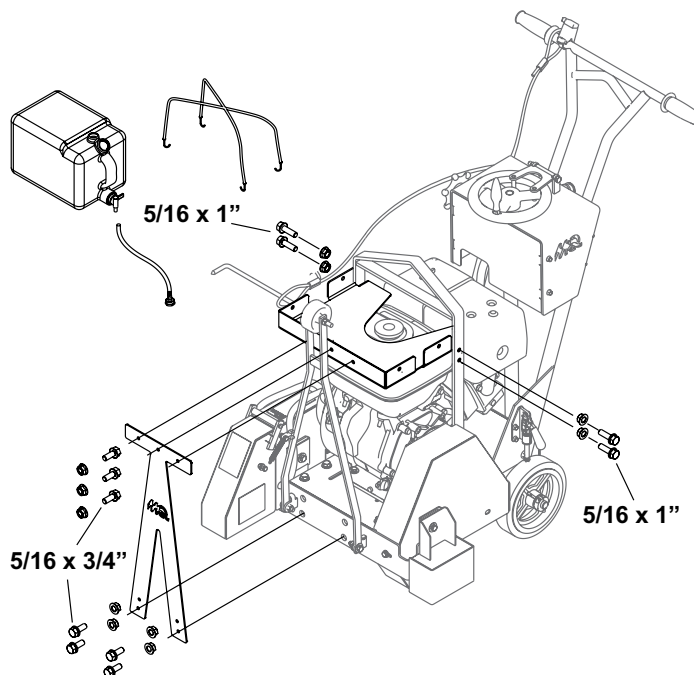


Figure 26. Water Tank Kit (Option)

## TROUBLESHOOTING (SAW)

### NOTICE

Certain operations referred to in this troubleshooting section such as re-seating valves or replacing piston rings may require special tools and must be performed by trained and competent personnel.

**Table 7. Blade Troubleshooting**

Symptom	Possible Problem	Solution
Blade slows or stops cutting.	Blade too hard for the material being cut?	Consult dealer or Multiquip for correct blade. Try cutting very soft material (sandstone, silica, brick, cinder block) to “redress” the blade.
	Engine torque diminished because of loose V-belt?	Tighten and/or replace V-belts.
	Insufficient engine power?	Check throttle setting. Check engine horsepower.
	Improper direction of rotation?	Check that the blade is properly oriented and rotational arrow points in a down-cutting direction.
	Blade is slipping on the bladeshaft?	Check that the blade and flange pins are properly installed on the bladeshaft.
Blade does not cut straight and/or true.	Blade being used on misaligned saw?	Check bladeshaft bearings and alignment integrity.
	Blade is excessively hard for the material being cut?	Check specification of the blade with the material being cut. Consult dealer or Multiquip for information.
	Blade being used at improper RPM?	Ensure blade surface feet per minute speed (SFPM) is approximately 6,000.
	Blade improperly mounted on arbor shoulders and flanges?	Ensure blade is properly affixed on the bladeshaft.
	Excessive force applied to blade while cutting?	DO NOT force the blade in the cut. Apply a slow and steady pace when sawing.
Blade discoloring, crackling and/or wearing excessively.	Blade too hard for the material being cut?	Consult dealer or Multiquip for correct blade. Try cutting very soft material (sandstone, silica, brick, cinder block) to “redress” the blade.
	Blade improperly mounted on arbor shoulders and flanges?	Ensure blade is properly affixed on the bladeshaft.
	Blade not receiving enough cooling water?	Ensure proper flow and volume of water is provided for wet cutting blades.
	Arbor hole out of round?	Ensure blade is properly affixed on the bladeshaft.
	Incorrect blade chosen for material being cut?	Check specification of the blade with the material being cut. Consult dealer or Multiquip for information.
	Excessive force applied to blade while cutting?	DO NOT force the blade in the cut. Apply a slow and steady pace when sawing.

## TROUBLESHOOTING (ENGINE)

Table 8. Troubleshooting (Engine)		
Symptom	Possible Problem	Solution
Difficult to start, "fuel is available, but no spark at spark plug."	Spark plug bridging?	Check gap, insulation or replace spark plug.
	Carbon deposit on spark plug?	Clean or replace spark plug.
	Short circuit due to deficient spark plug insulation?	Check spark plug insulation, replace if worn.
	Improper spark plug gap?	Set to proper gap.
	Ignition coil defective?	Replace ignition coil.
Difficult to start, "fuel is available and spark is present at the spark plug."	ON/OFF switch is shorted?	Check switch wiring, replace switch.
	Improper spark gap, points dirty?	Set correct spark gap and clean points.
	Condenser insulation worn or short circuiting?	Replace condenser.
	Spark plug wire broken or short circuiting?	Replace defective spark plug wiring.
Difficult to start, "fuel is available, spark is present and compression is normal."	Wrong fuel type?	Flush fuel system and replace with correct type of fuel.
	Water or dust in fuel system?	Flush fuel system.
	Air cleaner dirty?	Replace air cleaner.
	Choke open?	Close choke.
Difficult to start, "fuel is available, spark is present and compression is low."	Suction/exhaust valve stuck or protruded?	Re-seat valves.
	Piston ring and/or cylinder worn?	Replace piston rings and/or piston.
	Cylinder head and/or spark plug not tightened properly?	Torque cylinder head bolts and spark plug.
	Head gasket and/or spark plug gasket damaged?	Replace head and/or spark plug gaskets.
No fuel present at the carburetor.	Fuel not available in fuel tank (tank empty)?	Fill with correct type of fuel.
	Fuel filter clogged?	Replace fuel filter.
	Fuel tank cap breather hole clogged?	Clean or replace fuel tank cap.
	Air in fuel tank?	Bleed fuel line.
"Weak in power," compression is proper and does not misfire.	Air cleaner not clean?	Replace air cleaner.
	Improper fuel level in carburetor?	Check float adjustment
		Rebuild carburetor.
	Defective spark plug?	Clean or replace spark plug.
Improper spark plug gap?	Set to proper gap.	
Weak in power," compression is proper but misfires.	Water in fuel system?	Flush fuel system and replace with correct fuel type.
	Ignition coil defective?	Replace ignition coil.
	Dirty spark plug?	Clean or replace spark plug.
Engine overheats.	Wrong fuel type?	Flush fuel system and replace with correct fuel type.
	Spark plug heat value improper?	Replace with correct type of spark plug.
	Cooling fins dirty?	Clean cooling fins.
Rotational speed fluctuates.	Governor adjusted correctly?	Adjust governor.
	Governor spring defective or missing?	Replace governor spring.
	Fuel flow restricted?	Check entire fuel system for leaks or clogs.
Recoil starter malfunction?	Recoil mechanism clogged with dust and dirt?	Clean recoil assembly with soap and water.
	Spiral spring loose?	Replace spiral spring.

**CONFORMITY CERTIFICATES****SP118**

MULTIQUIP, INC. hereby declares that the machine(s) designated as SP118 conforms to the following:

1. American National Standards Institute - This machine has engineered and designed to fully comply with the requirements set forth in American Standards Institute (ANSI) B7.1-2000, "Safety Requirements for the Use, Care, and Protection of Abrasive Wheels".

American National Standards Institute

25 West 43rd Street, 4th Floor

New York, NY 10036

Tel: 212 642 4900

FAX: 212 398 0023

[www.ansi.org](http://www.ansi.org)

2. California Air Resources Board (CARB) - This machine is defined as a preempt Off-Road Application as related to the CARB standards. Within Construction Equipment; specifically as a Concrete Saw with engine power less than 19kW (25HP), CARB standards do not apply to this machine.

[www.arb.ca.gov/msprog/offroad/preempt](http://www.arb.ca.gov/msprog/offroad/preempt)

3. European Union (EU) - For members of the European Union (EU), this machine is designed to meet the following EU directives and standards:

**Declaration of Conformity:**

- SAFETY OF MACHINERY DIRECTIVE (Directive 98/37/EC).
- LOW VOLTAGE EQUIPMENT directive (73/23/EEC).
- ELECTROMAGNETIC COMPATIBILITY (EMC) directive (89/336/EEC).
- ELECTROMAGNETIC COMPATIBILITY (EMC) directive (89/336/EEC).  
in accordance with the EU standards EN 50081/1 and EN 55022
- NOISE directive (2000/14/EEC) in accordance with EU Standards EN ISO 3744.

Vice President of Manufacturing

J. Arnswald



**MULTIQUIP INC.**  
POST OFFICE BOX 6254  
CARSON, CALIFORNIA 90749  
310-537-3700 • 800-421-1244  
FAX: 310-537-3927  
E-MAIL: [mq@multiquip.com](mailto:mq@multiquip.com)  
[www.multiquip.com](http://www.multiquip.com)

# OPERATION MANUAL

## HERE'S HOW TO GET HELP

PLEASE HAVE THE MODEL AND SERIAL NUMBER ON-HAND WHEN CALLING

### UNITED STATES

#### **Multiquip Corporate Office**

18910 Wilmington Ave.  
Carson, CA 90746  
Contact: mq@multiquip.com

Tel: (800) 421-1244  
Fax (800) 537-3927

#### **MQ Parts Department**

800-427-1244  
310-537-3700

Fax: 800-672-7877  
Fax: 310-637-3284

#### **Service Department**

800-421-1244  
310-537-3700

Fax: 310-537-4259

#### **Warranty Department**

800-421-1244  
310-537-3700

Fax: 310-943-2249

#### **Technical Assistance**

800-478-1244

Fax: 310-943-2238

### MEXICO

#### **MQ Cipsa**

Carr. Fed. Mexico-Puebla KM 126.5  
Momoxpan, Cholula, Puebla 72760 Mexico  
Contact: pmastretta@cipsa.com.mx

Tel: (52) 222-225-9900  
Fax: (52) 222-285-0420

### UNITED KINGDOM

#### **Multiquip (UK) Limited Head Office**

Unit 2, Northpoint Industrial Estate,  
Globe Lane,  
Dukinfield, Cheshire SK16 4UJ  
Contact: sales@multiquip.co.uk

Tel: 0161 339 2223  
Fax: 0161 339 3226

### CANADA

#### **Multiquip**

4110 Industriel Boul.  
Laval, Quebec, Canada H7L 6V3  
Contact: jmartin@multiquip.com

Tel: (450) 625-2244  
Tel: (877) 963-4411  
Fax: (450) 625-8664

© COPYRIGHT 2012, MULTIQUIP INC.

Multiquip Inc, the MQ logo are registered trademarks of Multiquip Inc. and may not be used, reproduced, or altered without written permission. All other trademarks are the property of their respective owners and used with permission.

This manual MUST accompany the equipment at all times. This manual is considered a permanent part of the equipment and should remain with the unit if resold.

The information and specifications included in this publication were in effect at the time of approval for printing. Illustrations, descriptions, references and technical data contained in this manual are for guidance only and may not be considered as binding. Multiquip Inc. reserves the right to discontinue or change specifications, design or the information published in this publication at any time without notice and without incurring any obligations.

Your Local Dealer is:

